

Broaches re-sharpening

When the cutting edge has a radius of 0,02 – 0,05 mm the roughness of the machined surface is very bad and also the force required is around 30% higher.

If we regrind the broach when the wear is to this level it's necessary to remove only 0,06 – 0,08 mm, but if we waiting that the wear increases a lot, we need to remove more material, for example 0,3 - 0, 5 mm, whit a shorter life of the broach.

The roughness must be around $R_a = 0,2 \mu m$.

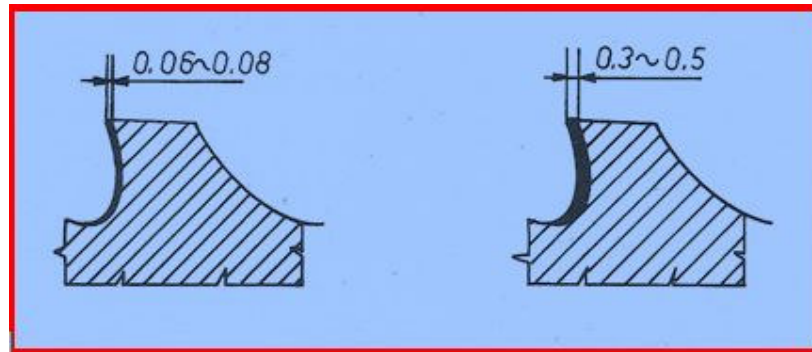

Fig. N°1

If the axis of the broach and the axis of the wheel are in the same plane, the wheel touch the face of the broach in two points.

In this case the marks of grinding wheel in the face have two direction and in the cutting edge is preset a lot of burrs.

On the contrary , if the axis of the grinding wheel is displaced out of the plan of the workpiece, the grinding wheel touch the face only in one point, the marks have one direction and the burr is smaller. (See fig. N°2).

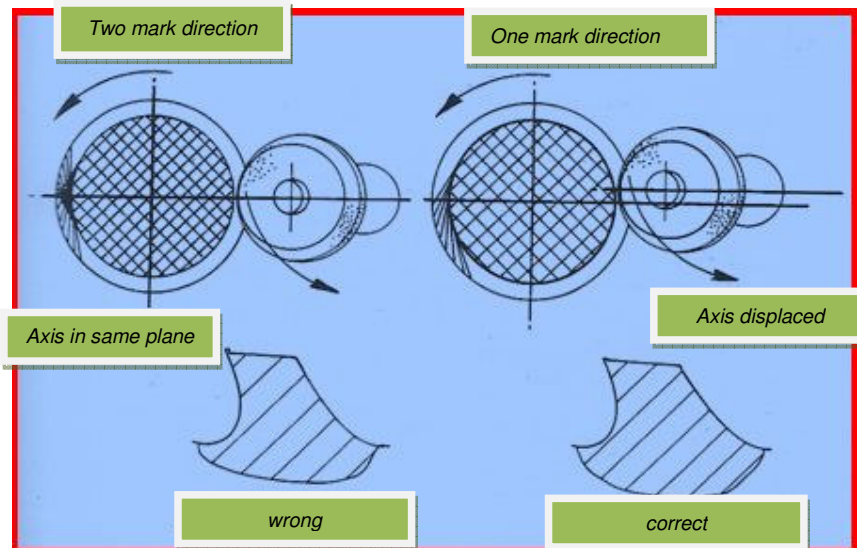

Fig. N°2



Fig.N°3- Resharpening of a broach of Sib Sideral- (Leini- Torino – Italy)

The most important point is to set correctly grinding wheel diameter and inclination angle of the wheel in order to obtain a correct rake angle.

The above two values are depending also of broach diameter.

It's valid the following formula.

$$D = 0,85 \cdot d \cdot \frac{\sin(\beta - \gamma)}{\sin \gamma}$$

Where:

D = grinding wheel diameter

d = outside diameter of the broach

β = grinding wheel inclination

γ = rake angle

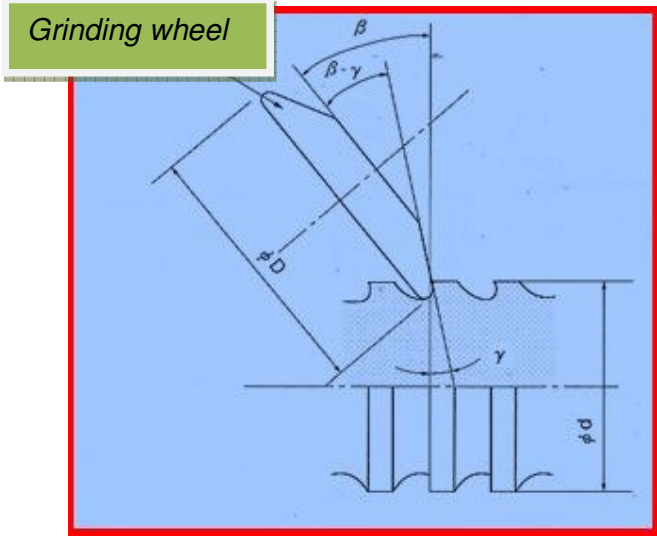

Fig. N°4

In the followings two tables are show the diameters of grinding wheel in according to the other parameters.

Table N°1 - Diameter of grinding wheel for round broaches

Broach Diameter d	Grinding wheel inclination $\beta=30^\circ$							Grinding wheel inclination $\beta=40^\circ$							
	Rake angle γ							Rake angle γ							
	7	9	12	14	16	18	20	7	9	12	14	16	18	20	
Diameter of grinding wheel								Diameter of grinding wheel							
8	21	15	10	-	-	-	-	27	19	13	10	-	-	-	
10	27	19	12	-	-	-	-	39	28	19	15	12	10	-	
12	32	23	15	11	-	-	-	46	33	23	18	15	12	10	
14	38	17	27	13	10	-	-	54	39	27	21	17	14	11	
15	41	29	19	14	11	-	-	58	42	28	23	18	15	12	
16	43	31	20	15	12	-	-	62	45	30	24	20	16	13	
18	49	35	22	17	13	10	-	70	50	34	27	22	18	15	
20	54	39	25	19	14	11	-	78	56	38	31	25	20	17	
22	60	43	27	21	16	12	-	85	61	42	34	27	22	18	
24	66	46	30	23	1	13	10	93	69	46	37	30	24	20	
25	68	48	31	24	18	14	11	97	70	48	38	31	25	21	
28	77	56	36	27	21	16	12	106	79	53	43	35	29	24	
30	82	6	38	29	22	17	13	114	84	57	46	38	31	26	
32	88	64	41	31	24	18	14	121	90	61	49	40	33	27	
35	96	70	44	34	26	20	15	132	98	67	54	44	36	30	
36	99	72	46	35	27	21	16	136	101	69	55	45	37	31	
38	104	76	48	37	28	22	17	144	107	72	58	48	39	32	
40	109	80	50	40	30	23	18	151	112	76	61	50	41	34	
42	115	84	53	41	31	24	19	159	118	80	64	53	43	36	
45	123	90	57	44	34	26	20	170	126	86	69	57	47	38	
48	131	95	61	46	36	28	21	182	135	91	73	60	50	41	
50	137	99	63	48	37	29	22	189	140	95	76	63	52	42	
55	150	109	70	53	41	32	24	208	154	105	84	69	57	47	

Table N^o 2 - Diameter of grinding wheel for round broaches

Broach Diameter d	Grinding wheel inclination $\beta=50^\circ$							Grinding wheel inclination $\beta=60^\circ$						
	Rake angle γ							Rake angle γ						
	7	9	12	14	16	18	20	7	9	12	14	16	18	20
	Diameter of grinding wheel							Diameter of grinding wheel						
8	38	28	20	15	13	11	-	44	33	23	19	17	14	12
10	47	35	25	20	17	14	12	55	42	29	24	21	18	16
12	57	42	30	25	20	17	14	69	50	35	29	25	22	19
14	66	50	35	29	24	20	17	78	59	41	34	29	25	22
15	71	53	37	31	26	21	18	83	63	44	36	32	27	24
16	76	57	40	33	27	23	19	89	68	47	39	34	29	25
18	85	64	45	37	31	26	22	100	76	53	44	38	33	28
20	95	71	50	41	34	29	24	111	84	59	49	43	36	32
22	105	78	55	45	38	32	27	123	93	65	53	47	40	35
24	114	86	60	49	41	35	29	134	101	70	58	51	44	38
25	119	89	62	50	43	36	31	139	105	73	61	53	46	40
28	137	100	72	58	50	41	35	156	118	84	71	60	51	45
30	147	108	77	62	54	44	37	167	126	90	76	64	55	48
32	158	115	82	66	57	47	40	178	135	96	81	69	59	51
35	172	125	89	72	63	51	43	195	147	105	88	75	64	56
36	176	129	92	74	64	53	45	200	151	107	91	77	66	58
38	186	136	97	78	68	55	47	212	160	114	96	81	70	61
40	195	143	102	82	71	58	50	222	168	120	101	86	74	64
42	205	150	107	87	75	61	52	234	177	125	105	90	77	67
45	220	160	115	93	80	66	56	250	190	135	113	96	83	72
48	234	172	122	99	86	70	60	268	202	143	121	103	88	77
50	244	178	127	103	89	73	62	278	210	150	126	107	92	80
55	268	197	140	113	98	80	68	311	232	164	138	118	101	88